



# Tamil Nadu Newsprint and Papers Limited

( A Government of Tamil Nadu Enterprise)

Kagithapuram - 639 136, Karur Dist. Tamil Nadu, India.

Phone : (0091) 04324 - 277001 to 277010

Fax : (0091) 04324 - 277025 Purchase : 277026

PMD : 04324 - 277027

Mktg : 277028 & 277029

HR : 04324 - 277273 Cell : 94860 41341 to 41343 Grams : NEWSPRINT

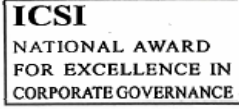

**TENDER NO : 242513002591**

**August 9, 2024**

M/s.

Dear Sirs,

Sub:	E - Tender for Procurement of TNPL COPIER A4-70 GSM & A4 80 GSM 10 REAMS CARTON LID & TRAY- Reg
Ref:	Press Tender No. 242513002591

TNPL would like to procure **TNPL COPIER A4-70 GSM & A4 80 GSM 10 REAMS CARTON LID & TRAY** against the above referred tender. In this connection please find the following:

1	E-tendering Terms and conditions	Annexure – I
2	Qualifying factors of the Tender	Annexure – II
3	General Terms and Conditions, Terms & Conditions for Reverse Auction and Process Compliance Statement	Annexure – III
4	Technical cum Commercial Bid	Annexure – IV
5	Price Bid schedule	Annexure – V

The tenderers are requested to go through the E- tendering terms & conditions, General terms & conditions of the Tender, Terms and Conditions for Reverse Auction (e-auction) and Process Compliance Statement carefully.

The due date for submission of Tender documents including the Technical Cum Commercial Bid and the Price bid through E-procurement portal (<https://tntenders.gov.in/nicgep/app>) is **22.08.2024 before 3:00 PM. The Technical Cum Commercial Bid will be opened through online portal at 04:00 PM on 23.08.2024.**

Contd..2



**TENDER No: 242513002591****(2)****TENDER OPENING AND TECHNICAL BID EVALUATION**

- a. **Technical Bid opening will be done online** and technical evaluation will be carried out after the due date of submission of online Bid.
- b. **TNPL will examine the Technical Bids against the Qualifying criteria and Technical cum Commercial bid given in the Tender document.**
- c. **Evaluation will be done based on the documents submitted by the Bidder. The Sample should conform to TNPL Specification.** The Bids which are not meeting Qualifying criteria will be rejected and further processing will not be carried out.
- d. Decision of TNPL is final and no dispute can be raised by any Bidder for rejection of their Bids and no claims on this account will be entertained.
- e. The Bidders whose Bids meet the Qualifying Criteria and Technical specifications of the tender will be called as **“Technically Qualified Bidders”**.
- f. In case if the Bidder fails to comply with the requirements of TNPL, such Bids will be rejected without entertaining further correspondence in this regard.

The technical offers excepting price Bid will be opened by TNPL tender opening committee at Purchase section, Kagithapuram through <https://tntenders.gov.in/nicqep/app>.

**Please note that the points asked for in Annexure-II are the qualifying factors of the Tender. Tenderers who do not comply with the conditions with documentary proof (wherever required) will not be qualified in the Tender for Price bid opening and E-reverse auction stage.**

**OPENING OF THE PRICE BIDS:**

The date and time of opening of Price Bids will be notified later through registered e-mail to the Bidders who fulfill the tender terms and conditions.

**Note: At the price bid stage, TNPL would adopt the following methodology to finalize the tender.**

1. Technical Bid is to be filled in the given format & uploaded.
2. **Price Bid (BOQ)** is to be filled in the given format & uploaded.
3. **In the e-tender, the price bids received from the technically qualified bidders will be opened electronically.**
4. **The opening price for the e-auction will be fixed by TNPL.** The opening price & the minimum bid decrement, the date and time of e-auction (<https://tntenders.gov.in/nicqep/app>) will be communicated to the qualified parties through their registered Mobile number and E-mail ID in NIC portal.
5. **The lowest offer received either through e-portal price bid (BOQ) or through e-auction whichever is lower, will only be considered for placement of order.**
6. Further, if the bidder's offer is not qualified as per the qualifying factors mentioned in the tender, their price bid (BOQ) will not be opened.

**Note : All the clarification in the document and specification at once shall be requested by E-mail to [purchase.packing@tnpl.co.in](mailto:purchase.packing@tnpl.co.in)**



**TENDER No: 242513002591**

**(3)**

**Submission of Tender Fee and Earnest Money Deposit (EMD):**

**Tenderers are requested to make tender fee and EMD payment through NIC Online payment gateway.**

**TENDER FEE:** In case, the tenderer has downloaded the tender document from websites, **Non-refundable Tender Fee of Rs.590/-** is to be remitted **through NIC online payment gateway.**

**EMD of Rs.50,000/- (Rupees Fifty Thousand) should be remitted through NIC online payment gateway.**

**The remittance details of Tender fee and EMD should be furnished in the Technical cum Commercial Bid. Further remittance statement / UTR details should be uploaded in the online procurement portal : <https://tntenders.gov.in/nicgep/app>**

- 1. The offer should be valid for a minimum period of 90 Days from the date of Reverse Auction / opening of price bid.** No bidder is permitted to withdraw his offer within the validity period of the tender or before finalization of the order. In case any bidder withdraws his offer within the validity period of the offer or before finalization of the order, the EMD amount paid by him will be forfeited.
- 2. Technical cum Commercial bids received without EMD are liable for rejection.** TNPL will not entertain any request for adjusting the EMD from the tenderer's due/running bills or from the EMD/Security Deposit of any other tender participated by the tenderer.

**NOTE:**

TNPL is not bound to accept the lowest quotation and TNPL may accept or reject the lowest quotation or any quotation at its sole discretion and go for re-tendering in case the lowest rate obtained in the tender is considered higher.

**TNPL reserve the right to reject any or all tenders at it's own discretion without assigning any reason whatsoever and TNPL is not responsible for any other delay in submission of online bid on due date and time (Server time) through E-tendering portal <https://tntenders.gov.in/nicgep/app>.**

Thanking you,  
Yours faithfully,  
for **TAMIL NADU NEWSPRINT AND PAPERS LIMITED,**

**DGM (PURCHASE)**

Encl: as above

**TENDER NO:242513002591****ANNEXURE – I: E-TENDERING TERMS AND CONDITIONS****INSTRUCTION TO BIDDERS FOR SUBMISSION OF ONLINE BIDS IN E-TENDER**

Techno-commercial bids and price bids should be submitted through the following link <https://tntenders.gov.in/nicgep/app>

The tender will be processed online through e-tender and e-reverse auction. The bidder shall submit his response through bid submission to the tender in the online procurement platform at NIC's website <https://tntenders.gov.in/nicgep/app>. No other forms of bid submission is accepted. Bidders are requested to quote their price through the online e-procurement portal/system only.

**The procedures to be followed are explained below:**

- a) Techno-Commercial Bids are to be filled in the given formats attached. The required and mandatory formats are available in the Tender Document in the e-portal.
- b) Price Bids are to be filled in the e-portal in the relevant web pages enabled for the bidders.

**Price bids will be opened before- reverse auction.**

- **Bidders are requested to read the instructions and terms & conditions carefully before submitting their online tenders.**
- The Bidders are required to submit soft copies of their Bids electronically on the TAMILNADU GOVERNMENT E PROCUREMENT Portal, using valid Digital Signature Certificates. The necessary instructions are given to assist the Bidders in registering on the TAMILNADU GOVERNMENT E PROCUREMENT Portal, prepare their Bids in accordance with the requirements and submitting their Bids online on the TAMILNADU GOVERNMENT E PROCUREMENT Portal.
- More useful information for submitting online Bids on the TAMILNADU GOVERNMENT E PROCUREMENT Portal may be obtained at: <https://tntenders.gov.in/nicgep/app>)

**The bidding under this contract is electronic bid submission through website <https://tntenders.gov.in/nicgep/app> only. Detailed guidelines for viewing bids and submission of online bids are given in the website. The bidder's can log on to this website and view the invitation for Bids and can view the details of Materials /works for which bids are invited.**

**1 REGISTRATION:**

- 1.1 The bidders need to submit the bids online. However, the bidders are required to have enrolment/registration in the website by clicking on the link "**Online bidder enrolment**" which is **free of charge**.
- 1.2 As part of the enrolment process, the bidders are required to choose a unique user name and assign a password for their accounts.
- 1.3 Bidders are advised to register their valid email address and mobile number as part of the registration process. These details would be used for any communication from the e-Portal.
- 1.4 Upon enrolment, the bidders are required to register their valid Digital Signature Certificate (DSC) (Class Class III Certificates with signing key usage) issued by any Certifying Authority recognized by CCA India (e.g. Sify / nCode / eMudhra etc.), with their profile.
- 1.5 **Only one valid DSC should be registered by a bidder.** Please note that the bidders should ensure that they do not lend their DSC to others which may lead to misuse.

Contd....2

**TENDER NO:242513002591**

[2]

- 1.6 Bidder then can login to the site through the secured login by entering their user ID / password and the password of the DSC / e-Token.

**2.0 CONTACT PERSONS:****For queries related to registration and online bidding (NIC):**

e-mail : support.etender@nic.in

Contact No.: 044 – 24461505 (OR)

**Mr. Pranesh (TNPL) for any support in NIC portal issues.**Contact no : : 04324 277001 - 10 (10 lines) **Extn. 2849 / Mobile:9489400798**E-Mail : [eps.support@tnpl.co.in](mailto:eps.support@tnpl.co.in).**3.0 SYSTEM REQUIREMENT:**

- i. Operating System: Windows 7 or above, RAM – 1GB and above
- ii. Internet connectivity with at least 2 Mbps speed
- iii. Internet browser: IE 9 and above (or) Mozilla Firefox 3.5 up to version 49
- iv. Signing type: Digital Signature (class III)
- v. JRE 8.0 software to be downloaded and installed in the system.

To enable ALL active X controls and disable 'use pop up blocker' under Tools→Internet Options→ custom level (Please run IE settings once)

**4.0 SEARCHING FOR TENDER DOCUMENT:**

- 4.1 There are various search options built in the Website, to facilitate bidders to search active tenders by several parameters. These parameters could include Tender ID, organization name, location, date, value, etc.
- 4.2 Once the bidders have selected the tenders they are interested in, they may download the required documents/tender schedules. These tenders can be moved to the respective 'My Tenders' folder. This would enable the Tamil Nadu Govt. e-Procurement Portal, to intimate the bidders through SMS / e-mail in case there is any corrigendum issued to the tender document.
- 4.3 The bidder should make a note of the unique Tender ID assigned to each tender, in case they want to obtain any clarification / help from the Helpdesk.

**5.0 PREPARATION OF BIDS:**

- 5.1 Bidder should take into account any corrigendum published on the tender document before submitting their bids.
- 5.2 Bidders are requested to go through the NIT and the tender document carefully to understand the documents required to be submitted as part of the bid. Please note the number of covers in which the bid documents have to be submitted, the number of documents including the names and content of each of the document that need to be submitted. Any deviations from these may lead to rejection of the bid.
- 5.3 Bidders, in advance, should get ready the bid documents to be submitted as indicated in the tender document and generally, they can be in PDF / XLS / RAR / DWF / JPG formats. Bid documents may be scanned with 100 dpi, which helps in reducing size of the scanned document. Since the uploaded documents shall be downloaded for evaluation of bid, bidders are advised to **upload clear scanned copies**.
- 5.4 The completed bid comprising scanned copy of the proof for the payment of EMD and necessary technical and commercial documents should be uploaded on the website along with signed and scanned copies of requisite certificates are mentioned in the different sections in the tender document.

**TENDER NO:242513002591**

[3]

**6.0 PROCEDURE FOR ELECTRONIC SUBMISSION OF BIDS:**

The bidder shall submit online the requirements under qualification criteria and Technical Documents required and Price Schedule/BOQ. All the documents are required to be signed digitally by the bidder. After electronic online bid submission, the system generates a unique bid reference number which is time stamped. This shall be treated as acknowledgement of bid submission.

- 6.1 Bidder should log- in to the site well in advance for Bid submission so that they can upload the Bid in time i.e. on or before the Bid submission time. Bidder will be responsible for any delay due to other issues.
- 6.2 The Bidder has to digitally sign and upload the required Bid documents one by one as indicated in the Bid document.

**Payment of Tender Fee and EMD:**

**6.3 Bidder has to select the payment option as "ONLINE" to pay the tender fee and EMD as applicable through NIC online payment gateway.**

Please read the instructions below before proceeding for online payment :

- **Remittance of Tender Fee & EMD should be made only in single transaction.**
- **Avoid last minute transaction of Tender fee & EMD. Please ensure to remit the Tender fee & EMD payment 2 - 3 days prior to tender due date.**
- **In case of any issue, please contact our helpdesk : [support.etender@nic.in](mailto:support.etender@nic.in) / [eps.support@tnpl.co.in](mailto:eps.support@tnpl.co.in).**
- **If payment is already done, but system is still showing "Pay Online" button. Please click on Pay Online >> SBI MOPS >> Submit >> Payment Verification. Once the payment status is updated on the portal, pay online button will disappear. If your account is debited, please wait till next working day for status update.**
- **If Payment status shows "Pending". Bidder should check the payment status on periodic basis till it shows success. The portal shows the current payment status as it is received from the bank. To check the current payment status, bidder may login into the account and click Pay Online >> SBI MOPS >> Submit >> Payment Verification.**
- **If your account is not debited, you can cancel the previous transaction by clicking on "cancel" button.**
- **After making a successful payment, if the bidder didn't complete the bid submission process or Freeze the bid by following due process, such bid will be considered as invalid and the total Fee / Amount (Tender Fee, EMD etc) paid will be automatically refunded to the bidder's account on the completion of Bid Opening (Technical Bid Opening) process by the Tender Inviting Authority.**
- **If the bidder withdrew its bid within due date & time then also the bid will be considered as invalid bid. In such cases, Total Fee/Amount (Tender Fee, EMD etc) will be automatically refunded to bidders account on the completion of Bid Opening (Technical Bid Opening) process by the Tender Inviting Authority.**

Contd....4

**TENDER NO:242513002591**

[4]

**Step by step procedure for making online payment:**

1. Tenderers are requested to remit Tender fee & EMD payment through NIC online payment gateway well in advance.
2. Click “Pay Online” when you reach below page while Online Bid Submission.

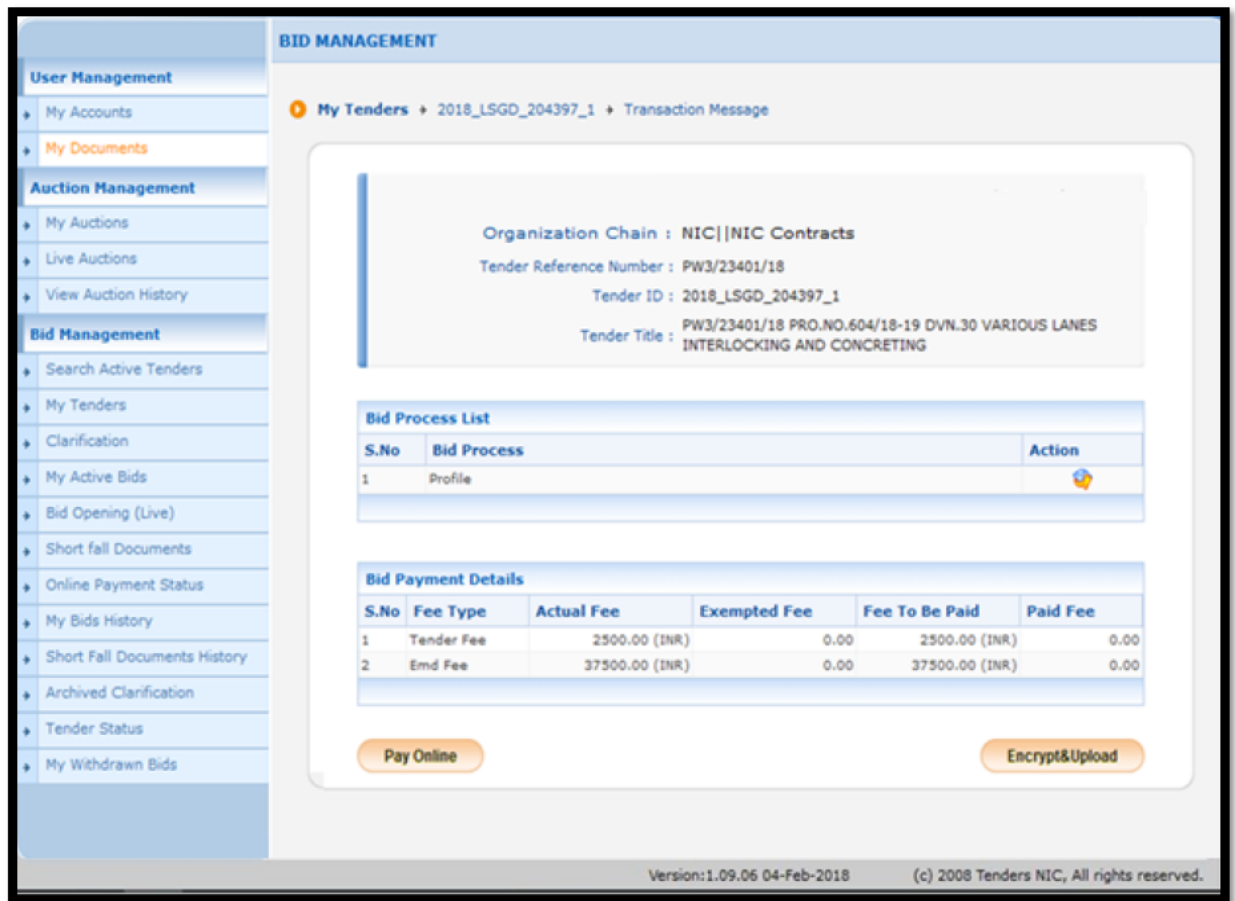

3. Click “**Confirm to Pay**” to proceed with the payment gateway
4. Verify the Tender fee and EMD shown are correct, as per tender document. Then, select the payment option **SBI MOPS** and Submit.
5. Read **Terms and Conditions**, and then click **Submit**.
6. Bidders should choose the type of transaction (i.e. Net Banking : SBI / Other Banks and Other Payment Modes : NEFT/RTGS)and proceed for payment.
7. Once the type of transaction is selected it navigates to the respective landing page. The step by step details for making payment (Net Banking : SBI / Other Banks) are given below:

Contd....5

**TENDER NO:242513002591****[5]****a) SBI : NET BANKING**

- Bidder with SBI account may click **SBI** option to proceed to its Net Banking Page
- Enter user ID and Password and Click on **Login** to proceed.
- After checking the payment details, Click **Confirm** button to transfer payment. After account debit, MOPS gateway will automatically re-direct to the eProcurement System, with the Success transaction.
- Then bidder will receive bank response immediately by verifying the payment status (click on **Pay Online >> SBI MOPS >> Submit >> Payment Verification**), whether it is **Successful** or not. In case, payment is debited from account and further, **Payment Failure** is shown, immediately contact the eProcurement helpdesk, for resolution, before tender closing time.
- If payment is successful, then Click **Next** to go to Bid Preparation details
- Please ensure that the **Pay Online** option (bid submission) should not appear after successful payment. Then bidder may proceed with **Encrypt and Upload** to upload tender documents, and further submission process.

**b) OTHER BANKS:**

- Bidders with other bank account may click **Other Banks** option to proceed to Net Banking Page.
- Bidder should select the appropriate Bank from selection page.
- After selecting the appropriate bank, Click Make Payment Button to proceed to its internet banking page. Further steps may depend on the Bank Procedure.
- After successful payment, system will direct you to payment confirmation page.
- Then bidder will receive bank response immediately by verifying the payment status (click on **Pay Online >> SBI MOPS >> Submit >> Payment Verification**), whether it is **Successful** or not. In case, payment is debited from account and further, **Payment Failure** is shown, immediately contact the eProcurement helpdesk, for resolution, before tender closing time.
- If payment is successful, then Click **Next** to go to Bid Preparation details
- Please ensure that the **Pay Online** option (bid submission) is not shown after successful payment.. From here, you may proceed with **Encrypt and Upload** to upload tender documents, and further submission process.

**Note: For other payment mode, please refer Bidder Manual for Online Payment in eProcurement Portal (Tender Fee, EMD & others) available at [www.tntenders.gov.in/nicgep/app](http://www.tntenders.gov.in/nicgep/app).**

Contd....6



**TENDER NO:242513002591**

[6]

- 6.4 Bidder should prepare and submit the EMD as per the instructions specified in the Bid document. (If applicable)
- 6.5 Bidders are requested to note that they should necessarily **submit their price Bids in the format provided (BOQ)** and no other format is acceptable. If the price Bid has been given as a standard BOQ format with the tender document, then the same is to be downloaded and to be filled by the Bidder. Bidders are required to download the BOQ file, open it and complete the Blue colored (unprotected) cells with their respective financial quotes and other details (such as name of the Bidder etc). **No other cells should be changed.** Once the details have been completed, the Bidder should save it and submit it online, **without changing the filename.** **If the BOQ file is found to be modified by the Bidder, the Bid will be rejected.**
- 6.6 **The server time (which is displayed on the Bidders' dash board) will be considered as the standard time for referencing the deadlines for submission of the Bids by the Bidders, opening of Bids etc. The Bidders should follow this time during Bid submission.**
- 6.7 All the documents being submitted by the Bidders would be encrypted to ensure the secrecy of the data. The data entered cannot be viewed by unauthorized persons until the time of Bid opening. The confidentiality of the Bids is maintained using the secured Socket Layer 128 bit encryption technology. Data storage encryption of sensitive fields is done. Any Bid document that is uploaded to the server is subjected to symmetric encryption using a system generated symmetric key. Further this key is subjected to asymmetric encryption using buyers/Bid openers public keys.
- 6.8 The uploaded Bid documents become readable only after the tender opening by the authorized Bid openers
- 6.9 Upon the successful and timely submission of Bid (i.e., after Clicking "Freeze Bid Submission" in the portal), the portal will give a successful Bid submission message & a Bid summary will be displayed with the Bid no. and the date & time of submission of the Bid with all other relevant details.
- 6.10 The Bid summary has to be printed and kept as an acknowledgement of the submission of the Bid.
- 6.11 In all cases, Bidders should use their own ID and Password along with Digital Signature certificate at the time of submission of their Bid.
- 6.12 During the entire e-tender process, the Bidders will remain completely anonymous to one another and also to everybody else.
- 6.13 The e-tender floor shall remain open from the pre-announced date & time till the specified due date & time.
- 6.14 The electronic Bid submitted during the e-tender process shall be legally binding on the Bidder. Any Bid will be considered as valid only if it is submitted in the prescribed format given in the Bid document.

**TENDER NO:242513002591**

[7]

- 6.15 It is mandatory that all the Bids are submitted with digital signature certificate otherwise the same will not be accepted by the system.
- 6.16 TNPL reserves the right to cancel or reject or accept or withdraw or extend the due date for submission of Bid as the case may be without assigning any reason thereof.
- 6.17 The NIC server time shall be treated as final and binding. Bids recorded in the server before the Bid closing time will only be treated as valid Bid. Bidders are, therefore, advised to submit their Bids well before the closing time of e-tender. If any Bid reaches the server after the Bid closing time as per server time, the same will not be recorded and no complaint in this regard shall be entertained. TNPL is not responsible for any sort of delay or the difficulties faced during the submission of Bids online by the Bidders due to local issues.
- 6.18 Bidders are advised to exercise caution in submitting their Bids in e-tender and e-Reverse Auction, as the case may be, to avoid any mistake. Bids once submitted can't be recalled.
- 6.19 Any order resulting from this Bidding process shall be governed by the terms and conditions mentioned in the Bid Documents.
- 6.20 No deviation to the technical and commercial terms & conditions are acceptable.
- 6.21 Bidders are required to sign in each page of the Bid specification.
- 6.22 TNPL may, at its discretion, extend the deadline for the submission of bids by amending the bidding document, in which case all rights and obligations of TNPL and bidders subject to the previous deadline shall thereafter be subject to the deadline extended.

**7.0 LATE BID:**

The Electronic bidding system would not allow any late submission of bids after due date and time, as per server time.

**8.0 MODIFICATION AND WITHDRAWAL OF BIDS:**

- 8.1 Bidders may modify their bids online before the deadline for submission of bids.
- 8.2 In case a bidder intends to modify his bid online before the deadline, the bidder need not make any additional payment towards the cost of bid processing. For bid modification and consequential re-submission, the bidder is not required to withdraw his bid submitted earlier. Modification and consequential re-submission of bids is allowed any number of times. **The last modified bid submitted by the bidder within the bid submission time shall be considered as the bid.** For this purpose, modification/withdrawal by other means will not be accepted. The bidder may withdraw his bid by uploading his request before the deadline for submission of bids, however, if the bid is withdrawn, the re-submission of the bid is not allowed.
- 8.3 No bid may be modified after the deadline for submission of Bids.

Contd....8

**TENDER NO:242513002591****[8]****9.0 ASSISTANCE TO BIDDERS:**

- 9.1 Any queries relating to the tender document and the terms and conditions contained therein should be addressed to the Tender Inviting Authority for a tender or the relevant contact person / email ID indicated in the Notice inviting tender.
- 9.2 Any queries relating to the process of online bid submission or queries in general may be directed to the 24x7 Central Public Procurement Portal Helpdesk.

It may be noted by the bidders that NIC is only a service provider for conducting the online bidding process against this tender and shall not be a party to any contract between TNPL and the successful bidder(s) subsequent to the bidding process.

**10.0 SUBMISSION OF HARD COPIES OF DOCUMENTS, IF REQUIRED**

The Bidders needs to submit all the documents through online submission. However, the required documents should be submitted in Hard copies after online submission, **if demanded from TNPL.**

**11.0 E – TENDER AND E- REVERSE AUCTION**

- 11.1 In e-tender, price Bids received from Technically Qualified Bidders only will be opened, electronically. **The opening price for the e-auction will be fixed by TNPL.** The opening price & the minimum bid decrement, the date and time of e-auction (<https://tntenders.gov.in/nicgep/app>) will be communicated to the qualified parties through their registered Mobile number and E-mail ID in NIC portal. Technically Qualified Bidders only will be allowed to participate in the E- Reverse auction process.
- 11.2 After opening of the Price Bid, the Bidders who shall become eligible to participate in the Reverse Auction as per the conditions stated in this Document, known as the Qualified Bidders, will be intimated about their qualification through notification on the <https://tntenders.gov.in/nicgep/app> website within their secured login as well as a system generated email. It shall be the sole responsibility of the Bidder to regularly check the <https://tntenders.gov.in/nicgep/app> website and log in to see whether they have qualified or not. TNPL will not be responsible for non-receipt of email by the Bidder and its consequences.
- 11.3 E-Bidding is the process of inviting final price offers from the Qualified Bidders through internet for the purpose of determination of the lowest Bidder (i.e the Bidder who submits the lowest price Bid in the Reverse Auction).
- 11.4 The Qualified Bidder will remain anonymous to other Qualified Bidders participating in the electronic Bidding process. The Qualified Bidder will be able to see the prevailing lowest price Bid, but the name of the current L1 Bidder at any point of time will not be displayed. The Qualified Bidder shall have to put his price Bid below the displayed current L1 Bid by decrement as specified in above point, to become the L1 Bidder. The lowest price obtained after completion of the Reverse Auction Process, shall be the Closing Price and the bidder quoting the same will be considered as the L1 bidder.
- 11.5 The electronic Bidding process for E-reverse auction will have a scheduled start and close time which will be displayed on screen. A Qualified Bidder will be able to put his price Bid after the start of Bid time and till the close time of electronic Bidding. The current server time (IST) will also be displayed on the screen. In the event a Bid is received during the last 10 (ten) minutes before the scheduled close time of electronic Bidding the close time of electronic Bidding will be automatically extended by 10 (ten) minutes from the last received Bid time to give equal opportunity to all other Qualified Bidders. This process of auto extension will continue till there is a period of 10 (ten) minutes during which no price Bids are received.

**TENDER NO:242513002591****[9]**

- 11.6 During the tender process for electronic Bidding the Bidder shall be required to sign their Bids with their respective digital signature certificate (DSC) which has been used to login. Any digital signature certificate other than the above shall not be acceptable for Bid submission by the system.
- 11.7 Bidders in their own interest are advised to get themselves acquainted with the electronic Reverse Auction process of (<https://tntenders.gov.in/nicgep/app>) by getting their Authorized Representative trained through demo electronic – Reverse Auction schedule at the link <https://demoetenders.tn.nic.in/nicgep/app>.

**12.0 ABOUT DIGITAL SIGNATURE CERTIFICATE:**

- 12.1 A Bidder shall be required to possess a valid Digital Signature Certificate (DSC) of signing type to be able to submit its Bid and to participate in the electronic Reverse Auction on <https://tntenders.gov.in/nicgep/app> website. For this purpose, Bidders shall be required to authorize its Authorized Signatory to procure a Class III DSC of signing type from any Certifying Authority or their authorized agencies in India.
- 12.2 The Bidder may note that only one user id will be mapped with a given DSC for the Authorized Representative. DSC once mapped with a particular user id of a Bidder will normally not be changed and therefore Bidders are advised to carefully select the DSC before forwarding the same to NIC for mapping.
- 12.3 The Digital Signature Certificate will be used to digitally sign the Bids that the Bidder will submit online.
- 12.4 It will be the sole responsibility of the Bidder and its respective Authorized Representative to maintain the secrecy of the password for the Digital Signature Certificate. The Bidder and its contact person shall be solely responsible for any misuse of the DSC and no complain / representation in this regard shall be entertained at any stage by TNPL

**13.0 TERMS AND CONDITIONS FOR E-REVERSE AUCTION:**

- 13.1 After completion of the online E-Reverse Auction, the lowest price shall be available for further processing.
- 13.2 If no Bid or single Bid is received in the Bidding system/website within the specified time duration of the online E-Reverse Auction then TNPL may scrap the online Reverse Auction process and may proceed with the lowest Price Bid received through e-tendering for further processing.
- 13.3 Only those Bidders whose offers are found to be technically and commercially Responsive, shall be eligible to participate in E-Reverse Auction process.
- 13.4 Online Reverse Auction shall be conducted by TNPL on a pre-specified date and time, while the Bidders shall be quoting from their own offices/place of their choice. Internet connectivity shall have to be ensured by Bidders themselves.
- 13.5 To ward-off contingent situation, Bidders are requested to make all the necessary arrangements/alternatives whatever required so that they are able to circumvent such situation and still be able to participate in the Reverse Auction successfully. Failure of power or loss of connectivity at the premises of Bidders during the Reverse Auction cannot be the cause for not participating in the Reverse Auction. TNPL shall not be responsible for such eventualities.

**TENDER NO:242513002591****[10]**

- 13.6 Bidders are advised to get fully trained and clear all their doubts such as refreshing of Screen, tender value being Bid, Bidding rules etc.
- 13.7 Upon receipt of the system report after completion of the Online Reverse Auction Closing Price will be considered for further processing. TNPL's decision on award of contract shall be final and binding on all the Bidders.
- 13.8 TNPL reserves the right to cancel/reschedule/extend the Reverse Auction process/tender at any time, before ordering, without assigning any reason.
- 13.9 TNPL shall not have any liability to Bidders for any interruption or delay in access to the site irrespective of the cause. In such cases, the decision of TNPL shall be binding on the Bidders.
- 13.10 Other terms and conditions shall be as per TNPL's Bidding documents and other correspondences, if any, till date.
- 13.11 Bidders are required to submit their acceptance to the stipulated terms and conditions before participating in the Reverse Auction
- 13.12 For the Reverse Auction technically and commercially acceptable Bidders only shall be eligible to participate.
- 13.13 Bidders shall ensure online submission of their 'Bid Price' within the Bidding Period.
- 13.14 Rules for Reverse Auction like event date, time, Bid decrement, extension etc. shall be as per the business rules, enumerated above, for compliance.
- 13.15 If the Bidder or any of his representatives are found to be involved in Price manipulation/ cartel formation of any kind, directly or indirectly by communicating with other Bidders, action as per extant TNPL guidelines, shall be initiated by TNPL.
- 13.16 The Bidder shall not divulge either his Bids or any other exclusive details of TNPL to any other Bidder.
- 13.17 Period of validity of Prices received through Reverse Auction shall be same as that of the period of validity of Bids offered.
- 13.18 Bidders may note that, although extension time is 10 minutes, there is a time lag between the actual placing the Bid on the local computer of the Bidder and the refreshing of the data on to the server for the visibility to the TNPL. Considering the processing time for data exchange and the possible network congestion, Bidders must avoid the last minute hosting of the Price Bid.
- 13.19 Participating Bidder will agree to non-disclosure of trade information regarding the purchase, identity of TNPL, Bid process, Bid technology, Bid documentation and Bid details.
- 13.20 It is brought to the attention of the Bidders that the Bid event will lead to the closing price only.
- 13.21 Technical and other non-commercial queries (not impacting price) can only be routed to the TNPL contact personnel indicated in the Bidding documents.

**TENDER NO:242513002591****[11]**

- 13.22 Order finalization and post order activities would be transacted directly between Successful Bidder and TNPL.
- 13.23 Order shall be placed outside the e-portal & further processing of the order shall also be outside the system.
- 13.24 In case of any problem faced by the Bidder during Reverse Auction and for all Bidding process related queries, Bidders are advised to contact the persons indicated in the Bid document.
- 13.25 TNPL will not be responsible for any PC configuration/Java related issues, software/hardware related issues, telephone line glitches and breakdown/slow speed in internet connection of PC at Bidder's end.
- 13.26 Bidders may note that it may not be possible to extend any help, during Reverse Auction, over phone or in person in relation to rectification of PC/Internet/Java related issues and Bidder may lose the chance of participation in the Bidding.
- 13.27 For access to the Bidding site, the following URL is to be used:  
<https://tntenders.gov.in/nicgep/app>.
- For user guidance please follow the manual which is there in the website.
- 13.28 No queries shall be entertained while e-Reverse Auction is in progress.
- 13.29 In case user ID is locked, you are requested to call helpdesk at  
<https://tntenders.gov.in/nicgep/app>)
- 14.0 The tenderers are requested to go through the General terms and Conditions of the Tender, Terms and Conditions for e-reverse Auction and Process Compliance Statement carefully and attach the signed Process Compliance Statement along with the Techno-Commercial Bid in NIC's e-procurement portal <https://tntenders.gov.in/nicgep/app>. All bids shall be prepared and submitted in accordance with the given instructions. The tenderer shall examine all instructions, forms, terms and conditions detailed in the specification and Annexure and submit the rates and other particulars called for in this specification, as per the instructions and formats uploaded herewith.

\*\*\*\*\*



**TENDER NO:242513002591**

**ANNEXURE – II – Qualifying factors of the tender**

1	Tenderer should be a Manufacturer (Registration Certificate should be uploaded). In case of Tenderer is a Dealer, Authorization Letter <b>in Original</b> from the Manufacturer and Copy of Registration Certificate of the Manufacturer are to be uploaded along with Technical bid without fail.
2	<b>The Manufacturing Unit should have an Automatic Online Drying System at present. The offers from those units who do not have this facility will not be considered.</b>
3	The Tenderer should have supplied Carton Lid and tray for minimum period of last two years to any Paper Industries. PO Copies / Documentary proof to be provided.
4	Submission of Tender fee of Rs.590/-
5	Submission of EMD amount of Rs.50,000/-
6	Submission and acceptance of Sample
7	Submission of tender within due date and time
8	Acceptance of price validity as per tender.
9	Tenderer should possess valid GST / PAN Registration (copy of Certificates to be uploaded)

**Note:**

Tenderers who do not comply with the above conditions will not be qualified in the tender for Reverse Auction / Price bid stage.

=====



TENDER NO: 242513002591

**ANNEXURE III - TERMS AND CONDITIONS****01. QUANTITY:**

ONE YEAR requirement of TNPL COPIER A4-70 GSM & A4 80 GSM 10 REAMS CARTON LID & TRAY is as below :

S.NO	MATERIAL DESCRIPTION	QTY (NO.)
1	TNPL COPIER A4-70 GSM 10 REAMS CARTON LID & TRAY	22,000
2	TNPL COPIER A4 80 GSM 10 REAMS CARTON LID & TRAY	44,000

The quantity indicated is only approximate and it may vary on either side. TNPL does not guarantee for the same. In case required, TNPL may propose additional quantity on the supplier/s during the validity period and the supplier shall supply the material as per the rate, terms and conditions of the Purchase order.

**02. SPECIFICATION:-**

SPECIFICATION FOR **TNPL COPIER A4 80 GSM 10 REAM CARTONS LID / TRAY**  
(FOR TAMIL NADU GOVT ONLY), ITEM CODE : 5402900048

**I. TECHNICAL REQUIREMENTS FOR CARTON LID AND TRAY:**

S.NO	PARAMETER	TECHNICAL REQUIREMENT
1	Number of plies	3 plies Front layer=ply white liner Kraft Middle & back layer Kraft board with min 24bf.
2	Tray plies GSM	Top =200 g/m <sup>2</sup> Middle =180 g/m <sup>2</sup> Back =200 g/m <sup>2</sup>
3	Lid plies GSM	Top =200 g/m <sup>2</sup> Middle =180 g/m <sup>2</sup> Back =200 g/m <sup>2</sup>
4	Tray GSM	600±10%
5	Lid GSM	600±10%
6	Direction of flute	Lid= Parallel to the lengthier side of the lid & Tray= Parallel to the height of the tray
7	Type of flute	'B' flute( 6 mm) & height 2.8mm ± 1mm/ Min 45 flutes per 1 feet
8	Outer dimension of lid(length/width/height)	444mm,315mm,85mm
9	Outer dimension of tray(length/width/height)	436mm,307mm,250mm
10	Printing process	Four colour offset / flexo/gravure with scuff proof aqueous varnish
11	Odour	Lid and tray should be Odorless

**II. QUALITY SPECIFICATION:**

S.NO	PARAMETER	UOM	SPECIFICATION	REMARKS
1	Bursting strength for Tray	kg/cm <sup>2</sup>	Min 9.0	Control
2	Bursting strength for Lid	kg/cm <sup>2</sup>	Min 9.0	Control
3	Moisture for Tray	%	Max.10.00	Control
4	Moisture for Lid	%	Max.10.00	Control



TENDER NO: 242513002591

/2/

**III. DEDUCTION CLAUSE:**

Deviation from the Norms of Tray & lid		REMARKS
For bursting strength	8.5 to 8.9 kg/cm <sup>2</sup>	Acceptable with single proportionate deduction on the landed cost of the material.
	8.0 to 8.4 kg/cm <sup>2</sup>	Acceptable with double proportionate deduction on the landed cost of the material.
	Less than 8.0 kg/cm <sup>2</sup>	Material will be rejected
For moisture	10.1 to 15.0 %	Acceptable with double proportionate deduction on the landed cost of the material.
	More than 15.0%	Material will be rejected
<b>Note:</b> <ul style="list-style-type: none"> <li>In case of more than 3 loads get rejected during the validity of the contract period, the contract may be cancelled at the discretion of TNPL.</li> <li>The pro rata and rejection clause is applicable for entire lot if either Lid or Tray is deviated with specified norms.</li> </ul>		

**IV. GENERAL INSTRUCTION FOR TEXT CONTENT/COLOUR SCHEME & APPROVAL:**

- **As per the Lid/Tray samples or soft copy provided by TNPL, color scheme/design (Art work) to be prepared. On approval of the sample only, the bulk supplies to be made.**
- Sufficient stiffness to be maintained at both Lid and Tray folding portion to ensure travel into belt feeder.
- In both Lid and Tray, punching mark to be carried out at gum pasting area.
- Surface and printed matter of entire box should not be affected during the transit. To ensure the same **Aqueous coating shall be carried out without lamination/plastic film.**
- To ensure the quality and performance of the supplied Lid and Tray during transit, Scuff proof rub test and Surface energy (dyne test) will be made if required.
- Printed quality of the Lid and Tray should be sharp, clear and appealing.
- Lid and Tray should be flat in condition for trouble free operation
- Lid & tray should be separately packed with waste kraft and should strapped neatly to avoid transit damage

**V.OUTLINE DRAWING OF TNPL A4-10 REAMS CARTONS LID/TRAY**

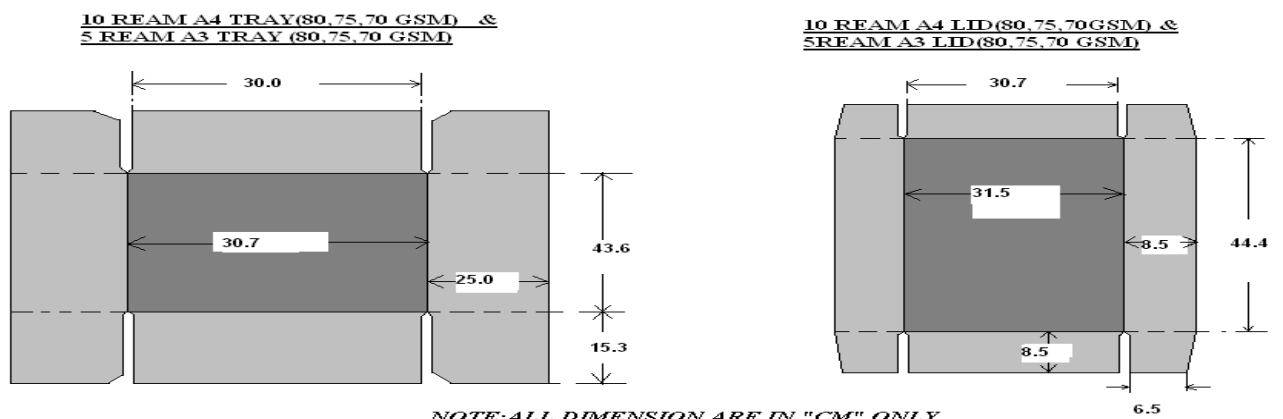

**SPECIFICATION FOR TNPL COPIER A4 70 GSM 10 REAM CARTONS LID/TRAY (FOR TAMIL NADU GOVT ONLY), ITEM CODE : 5402900049**

**I. TECHNICAL REQUIREMENTS FOR CARTON LID AND TRAY:**

S.NO	PARAMETER	TECHNICAL REQUIREMENT
1	Number of plies	3 plies Front layer=ply white liner Kraft Middle & back layer Kraft board with min 24bf.
2	Tray plies GSM	Top =200 g/m <sup>2</sup> Middle =180 g/m <sup>2</sup> Back =200 g/m <sup>2</sup>
3	Lid plies GSM	Top =200 g/m <sup>2</sup> Middle =180 g/m <sup>2</sup> Back =200 g/m <sup>2</sup>
4	Tray GSM	600±10%
5	Lid GSM	600±10%
6	Direction of flute	Lid= Parallel to the lengthier side of the lid & Tray= Parallel to the height of the tray
7	Type of flute	'B' flute( 6 mm) & height 2.8mm ± 1mm/ Min 45 flutes per 1 feet
8	Outer dimension of lid(length/width/height)	444mm,315mm,85mm
9	Outer dimension of tray(length/width/height)	436mm,307mm,250mm
10	Printing process	Four colour offset / flexo/gravure with scuff proof aqueous varnish
11	Odour	Lid and tray should be Odorless

**II. QUALITY SPECIFICATION:**

S.NO	PARAMETER	UOM	SPECIFICATION	REMARKS
1	Bursting strength for Tray	kg/cm <sup>2</sup>	Min 9.0	Control
2	Bursting strength for Lid	kg/cm <sup>2</sup>	Min 9.0	Control
3	Moisture for Tray	%	Max.10.00	Control
4	Moisture for Lid	%	Max.10.00	Control

**III. DEDUCTION CLAUSE:**

Deviation from the Norms of Tray & lid		REMARKS
For bursting strength	8.5 to 8.9 kg/cm <sup>2</sup>	Acceptable with single proportionate deduction on the landed cost of the material.
	8.0 to 8.4 kg/cm <sup>2</sup>	Acceptable with double proportionate deduction on the landed cost of the material.
	Less than 8.0 kg/cm <sup>2</sup>	Material will be rejected
For moisture	10.1 to 15.0 %	Acceptable with double proportionate deduction on the landed cost of the material.
	More than 15.0%	Material will be rejected
<b>Note:</b>		
<ul style="list-style-type: none"> <li>In case of more than 3 loads get rejected during the validity of the contract period, the contract may be cancelled at the discretion of TNPL.</li> <li>The pro rata and rejection clause is applicable for entire lot if either Lid or Tray is deviated with specified norms.</li> </ul>		

**TENDER NO: 242513002591**

/4/

**IV. GENERAL INSTRUCTION FOR TEXT CONTENT/COLOUR SCHEME & APPROVAL:**

- **As per the Lid/Tray samples or soft copy provided by TNPL, color scheme/design (Art work) to be prepared. On approval of the sample only, the bulk supplies to be made.**
- Sufficient stiffness to be maintained at both Lid and Tray folding portion to ensure travel into belt feeder.
- In both Lid and Tray, punching mark to be carried out at gum pasting area.
- Surface and printed matter of entire box should not be affected during the transit. To ensure the same **Aqueous coating shall be carried out without lamination/plastic film**
- To ensure the quality and performance of the supplied Lid and Tray during transit, Scuff proof rub test and Surface energy (dyne test) will be made if required.
- Printed quality of the Lid and Tray should be sharp, clear and appealing.
- Lid and Tray should be flat in condition for trouble free operation
- Lid & tray should be separately packed with waste kraft and should strapped neatly to avoid transit damage

**V.OUTLINE DRAWING OF TNPL A4-10 REAMS CARTONS LID/TRAY**

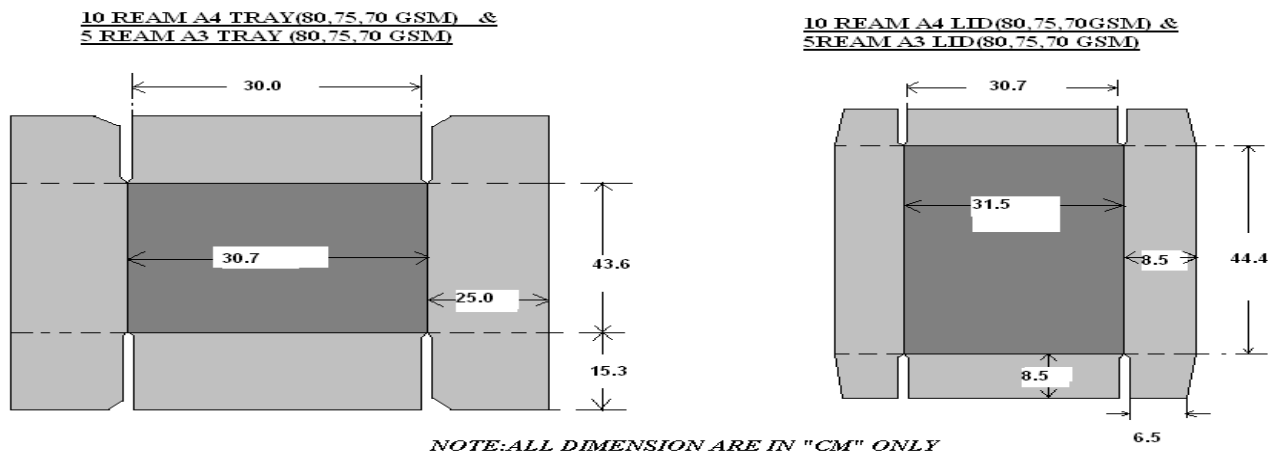

**03. QUALITY:**

Quality is the essence of this tender. The supplier shall supply the material strictly as per the specification mentioned above. The material supplied will be inspected at our factory. Quantity as ascertained on receipt of material at our site will be treated as quantity supplied wherever the package/materials are received intact. For each supply/consignment, test/quality certificate should be sent without fail. **As regards quality, our laboratory analysis report will be final and our decision on acceptance or rejection will be final and binding on you.**

**04. VALIDITY:**

The rate quoted should be valid for a minimum period of **90 Days from the date of Reverse Auction held / opening of Price Bid**. During the validity period, bidder is not permitted to make any upward revision in the rate. The order shall be kept valid for a period of **ONE YEAR** from the date of released of purchase order. During the validity period of the order, no upward revision in price will be allowed except in case of increase in statutory levies.



[5]

**05. TRANSPORTATION:**

It is the responsibility of the supplier to arrange transportation and supply the material on F.O.R. Destination basis. TNPL requires the material on **F.O.R. Kagithapuram** basis only. Otherwise the offer is liable for rejection.

**06. TERMS OF PAYMENT:**

100% payment will be made within 35 days from the date of receipt of materials subject to acceptance by RTGS Scheme.

Please provide the following details **duly certified by your bankers** to the undersigned for onward submission to our Accounts Department:-

- |                     |                   |
|---------------------|-------------------|
| 1. Name of the Bank | 3. Branch Code    |
| 2. Branch Name      | 4. Account Number |

**07. DUTIES AND TAXES:**

Goods and Service Tax (GST), taxes etc if applicable should be mentioned clearly and separately with the percentage of duties and taxes applicable.

**GST:**

Duplicate copy of GST invoice should be sent along with each supply for the purpose of availing GST credit. Copy of GST invoice should be sent in a separate cover addressed to **DGM (TOS, Stores & Disposal)** as may be specified in the purchase order. Without copy of GST invoice, material will not be unloaded.

**08. DELIVERY:**

**In the event of an order, you shall be in a position to start supplies within short notice and dispatches are to be effected as per delivery schedule given by TNPL from time to time.**

**09. DELAY OR NON DELIVERY:**

Time is the essence of the contract and completion of delivery dates agreed to are binding on the seller. In the event the seller is not able to supply as per the delivery schedules given by TNPL, Purchaser will have a right either to cancel the order without prejudice to any other rights or to make purchase from an alternate source at the risk and cost of the seller.

**10. SAMPLE:**

**All the vendors should submit 5 Nos. of Plain Sample boxes in TNPL COPIER A4-70 GSM & A4 80 GSM 10 REAMS CARTON LID & TRAY without printing matter strictly as per specification given S.No:2 directly to DGM (Purchase), TNPL, Kagithapuram, Karur 639136.**

In case of non-receipt of sample, **the tender will not be considered**. Those who fail to submit the sample in time and whose sample is not found acceptable, their tender will not be considered. The tenderers are expected to submit only one sample meeting our requirement. In case of any tenderer submits more than one sample, only one sample will be tested and the result of such sample will be considered for evaluation purpose.

**Contd...6**



TENDER. NO: 242513002591

[6]

**All boxes are in four colour printing. The successful tenderer shall be provided with the art work. After receipt of artwork, the box as per specification should be carried out and sample boxes are to be submitted for our approval. On approval only, bulk supply should be made. Please note that each consignment of boxes shall be tested and on approval, the consignment will be accepted.**

**Please ensure that the SAMPLE should reach us on or before 22.08.2024.** TNPL will not be responsible for any delay in receipt of sample and sample received after **22.08.2024** will not be accepted. Tenders containing inadequate sample will not be considered. The test result of TNPL will be final and binding and no dispute will be entertained.

**TNPL Technical team may visit the Tenderer's works, if required to assess the technical capability / capacity and to check the manufacturing facilities before considering them for the tender.**

**11. SUBMISSION OF INVOICE:**

Original Invoice should be sent along with each consignment in a separate sealed cover addressed to **DGM (TOS, Stores & Disposal)**. Without the receipt of invoice along with the material, the consignment will not be received / unloaded. **You should send 5 copies of invoice along with the truck. Original Invoice-1, Duplicate copy-1, Triplicate copy-1, Extra copies- 2.**

- a) In case of aggregate turnover of the Vendors in any of the preceding financial years from 2017-18 onwards is more than the aggregate turnover notified under sub-rule (4) of rule 48 then e-invoice is mandatory. The limit is Rs.20 Crore upto 30.09.2022 and Rs.10 Crore w.e.f 01.10.2022.
- b) In case of aggregate turnover of the company in any of the preceding financial years from 2017 – 18 onwards is less than the aggregate turnover notified under sub-rule (4) of rule 48, **then an undertaking to this effect shall be given by the Vendor in its letter head by Authorized Signatory along with a copy of the latest audited financials of the Company.**
- c) **In case of exemption in preparing e- invoice, then the Vendor needs to submit a declaration as under :**  
"I/We hereby declare that though our aggregate turnover in any preceding financial year from 2017-18 onwards is more than the aggregate turnover notified under sub-rule (4) of rule 48, we are not required to prepare an e-invoice in terms of the provisions of the said sub-rule"
- d) **If the value of the goods supplied is more than the specified limit as under then E-way bill is mandatory for transportation of goods.**
  - **Rs.50,000 for inter-state movement of goods**
  - Rs.1,00,000 for intra-state movement of goods (within TN)**

Contd...7



TENDER. NO: 242513002591

[7]

12. **REJECTION:**

TNPL requires **TNPL COPIER A4-70 GSM & A4 80 GSM 10 REAMS CARTON LID & TRAY** as per our specification given in S.No.2 above. Material not meeting our specification will be rejected outright and replacement should be made within 7 days from the date of intimation. The rejected material shall be taken back within 7 days from the date of intimation. Otherwise, the rejected material will be sent back to you at your risk and cost without any financial commitment to TNPL.

13. In case of rejection and failure to replace goods, the order will be treated as incomplete and we may cancel the order and will arrange to purchase the goods from elsewhere at your risk and cost and the purchase order released on you will be cancelled and action will be taken as per the order terms

14. **All the bidders are required to pay an EMD of Rs.50,000/- (Rupees Fifty Thousand Only) through "NIC ONLINE PAYMENT GATEWAY". The remittance details of EMD should be uploaded in the online procurement portal : <https://tntenders.gov.in/nicgep/app>.**

15. The EMD of the successful bidder will be converted into Security Deposit. This amount will not bear any interest and will be refunded on satisfactory completion of the order. This amount shall stand forfeited in the event of cancellation of order due to unsatisfactory performance of the seller.

16. The tender should be valid for a minimum period of **90 days from the date of Reverse Auction / opening of Price Bid**. No bidder is permitted to withdraw his offer within the validity period of the tender or before finalization of the order. **In case any bidder withdraws his offer within the validity period of the offer or before finalization of the order, the EMD amount paid by him will be forfeited and they will not be considered for future tenders.**

17. The suppliers are permitted to deal only with the Purchase Department.

18. **TNPL is not bound to accept the lowest quotation and TNPL may accept or reject the lowest quotation or any quotation at its sole discretion without assigning any reason whatsoever.**

19. **CANCELLATION:**

**In the event of unsatisfactory performance in executing the order with regards to quality and delivery schedule as per the terms, the order is liable for cancellation.** In the event of cancellation, the Security Deposit will be forfeited. TNPL reserves the right to exercise the Risk Purchase Option given in the General Terms and conditions of the tender. Also the TNPL reserves its right to cancel the order in full or part thereof without giving any reason by giving 15 days notice if the material is not required due to any reason.

20. **RISK PURCHASE:**

**In the event of PURCHASER terminating the contract in whole or in part due to poor performance with regards to quality and delivery schedule,** they may procure on such terms and in such manner as they deem appropriate, supplies similar to those so terminated and the SELLER shall be liable to the PURCHASER for any excess cost for similar supplies. However, in case of part termination of contract by the PURCHASER, the SELLER shall continue the performance of the contract to the extent it is not terminated under provisions of this clause.



TENDER. NO: 242513002591

[8]

**21. FORCE MAJEURE CLAUSE:**

If, at any time during the continuance of the contract, the performance in whole or in part of any obligations under this contract shall be prevented or delayed by reasons of any war, hostility, acts of public enemy, acts of civil commotion, strikes, lockouts, sabotages, fire, floods, explosions, epidemics, quarantine restrictions or other acts of God, Acts of Government in the country of Origin (hereinafter referred to as eventualities) then provided notice of the happening of any such eventualities is given by the Supplier within 7 days from the date of occurrence thereof, neither party shall, by reasons of such eventuality, be entitled to terminate this contract not shall have any claim for damages against the other. Deliveries under this contract shall be resumed as soon as practicable after such eventuality has come to an end or ceased to exist. Provided that if the performance in whole or part by the Supplier or any obligation under this contract is prevented or delayed by reasons of any eventuality for a period exceeding 30 days, TNPL may at its option terminate this contract by notice in writing.

**22. CORRESPONDENCE:**

All correspondence concerning the tender shall state the tender No and due date and shall be addressed to **CGM (COMMERCIAL), Tamil Nadu Newsprint and Papers Limited, Kagithapuram - 639 136, Karur District, Tamil Nadu.**

**23. COVERING LAW AND JURISDICTION:**

Notwithstanding anything contained herein, is hereby agreed that only the Courts at Chennai shall have exclusive jurisdiction for the adjudication of any disputes between the parties hereto, to the specific exclusion of all other courts.

**24. Supplier should possess Energy, Environment and / or Quality Standard Certificate as applicable to their line of Business (ISO 50001: 2018, ISO 14001 : 2015 and ISO 90001: 2015). If so, please provide the supporting documents of the same.**

**25. TNPL reserves the right to split the order on more than one vendor.**

**26. INFORMATION / DOCUMENTS:**

Tender should provide true and correct information /documents wherever asked for in the tender. At any point of time, if the information/ supporting documents provided by the tenderer is false / fabricated, tenderer's offer shall be disqualified automatically.

**27. PACKING:**

If the material is supplied in the plastic packing, the same should comply with Extended Producer Responsibility (EPR) under Plastic Waste Management, Rules 2016 and its subsequent amendments

---

**TENDER NO:242513002591****ANNEXURE III****TERMS AND CONDITIONS FOR E-REVERSE AUCTION:****Contact Details:**

Mr. S. Shanmuga Kumar DGM (Purchase)	Phone	04324-277 001 (Extn.2679)	Fax	04324 – 276 368
	e-mail	<a href="mailto:shanmugakumar.s@tnpl.co.in">shanmugakumar.s@tnpl.co.in</a> / <a href="mailto:purchase.packing@tnpl.co.in">purchase.packing@tnpl.co.in</a>		

**Selection process of vendors:**

- Bidders must submit the Process Compliance Statement duly signed, to TNPL along with Technical-cum-Commercial bid.
- TNPL will open the Price Bids of technically qualified bidders in the e-procurement portal. Subsequently, TNPL would communicate the Opening Price, Bid decrement and date and time of Reverse Auction to registered Mobile number and E-mail.
- On the event date, Vendors shall submit bids from their computers through Internet on <https://tntenders.gov.in/nicgep/app>. As and when other bidders place the bids, they would have the opportunity to revise their bids downwards if they wish to do so.
- Bidders must communicate their final bid break up details by Fax or E-mail to TNPL immediately after the bid event (Reverse auction). This may be followed by a hard copy communication of price by Post or Courier.
- At the end of the sourcing event, TNPL will have a list of all the bidders with their final bids, and will decide on awarding the business based on the comprehensive value proposition of each Bidder.
- TNPL's decision on the award shall be final and binding.

**All other terms and conditions are as per TNPL tender.**

**Bidding Price Format:** Bidders should quote the **Rate per NUMBER in INR.**

**Opening Price:**

- Opening price is defined as the highest initial price.
- Bidders can bid lower than the Opening Price.

**Currency:** All the Bidders must quote in the currency as informed by TNPL.

**Bid Decrement:**

Bid Decrement is the minimum fixed amount by which the next bid value can be decreased.

**Bid event format:**

This bid event will be conducted in Standard English Price Bid Event, with Alias Name Format.

**Quantity/Specifications/Terms and Conditions:**

Please refer the Annexure - I for the above details.

**Bidding Time & date:** Will be communicated to your registered mobile number/ E-mail by NIC separately.

**EVENT INFORMATION****Extension Rule:**

- There would be system generated Auto Extensions of 10 minutes each, if there is a bid placed by any participating supplier(s) in the last 10 minutes before the scheduled close time of electronic Bidding
- Extension of 10 minutes would happen for any number of times, if bid(s) is/are placed in the last 10 minutes.
- Extension will cease to occur, if no bid(s) are placed in the last 10 minutes.

**Illustration:**

- **For closing time at 15:00 hours:** If a bid is placed between 14:50 Hours to 15.00 hours (say 14.57), the bidding would be extended till 15.10 hours.
- If no bids are placed between 14:50 hours to 15.00 hours, the bidding will conclude at 15.00 hours.

**Validity:**

The bidders should keep their bids valid for a period of **90 days** from **the date of Reverse Auction / opening of Price Bid**. No bidder is permitted to withdraw his quoted rate within the validity period. **In case of withdrawal of offer, EMD will be forfeited** and TNPL may claim additional expenses, if any incurred, from the bidder due to withdrawal of offer by him.





**PROCESS COMPLIANCE STATEMENT FOR E-REVERSE AUCTION**

Bid event to be held for procurement of	TNPL COPIER A4-70 GSM & A4 80 GSM 10 REAMS CARTON LID & TRAY	TNPL Tender No	242513002591
-----------------------------------------	--------------------------------------------------------------	----------------	--------------

Name of the Organization: \_\_\_\_\_

The following terms and conditions are deemed as accepted by us for participation in the above bid event.

We have accepted the auction rules on participation at the bid event. The award decision by TNPL would be final and binding on us.

1. We will not divulge either our bids or those of other Vendors to any other external party.
2. We agree to non-disclosure of trade information regarding the purchase, identity of TNPL, bid process, bid technology, bid documentation and bid details.
3. Inability to bid due to telephone line glitch, Internet response issues, software or hardware hangs will not be the responsibility of TNPL.
4. Based on the competitive quotes received, TNPL's decision will be final and binding on us.
5. Our participation in a bid event is by invitation from TNPL.
6. TNPL is not obliged to place the contract if the expected price of the lots or event is not met. TNPL will be at liberty to cancel the bid event and initiate a fresh one, if necessary.
7. Bids once made cannot be withdrawn or modified under any circumstances.
8. TNPL can decide to extend, reschedule or cancel the auction.
9. Bids cannot be increased. Subsequent bids from the same supplier need to be lower by at least the minimum bid decrement from the lowest bid.
10. We shall indemnify and hold TNPL, its and their successors and assigns, officers, employees and agents harmless from any direct or indirect loss or damage and or claims for personal injury or property damage caused by any contractual problems or by our negligent or fraudulent act, omission or willful misconduct or breach of any term of this Agreement.
11. TNPL or its employees or other representatives will not be liable for damages arising out of or in connection with the use of this site. This is a comprehensive limitation of liability that applies to all damages of any kind, including (without limitation) compensatory, direct, indirect or consequential damages and claims of third parties.
12. TNPL does not guarantee continuous, uninterrupted or secure access to its services, and operation of the site may be interfered with by numerous factors outside of its control.

13. **Validity:**

The bidders should keep their bids valid for a period of **90 days** from **the date of Reverse Auction / opening of Price Bid**. No bidder is permitted to withdraw his quoted rate within the validity period. **In case of withdrawal of offer, EMD will be forfeited** and TNPL may claim additional expenses, if incurred, from the bidder due to withdrawal of offer by him.

We agree to have read, understand and agree to abide by this statement.

Organization	
Name	
Designation	
Signature & stamp /seal	
Date & Place	



TENDER NO: 242513002591

**ANNEXURE IV****TECHNICAL CUM COMMERCIAL BID****NOTE:**

- A. Before filling up the details, please carefully read all the points. No correction or overwriting is allowed.
- B. The last date for submission of tender is **22.08.2024 before 3.00 PM.**
- C. No late tender will be entertained and TNPL will not be responsible for any delay in submission of bid through NIC on due date and in time.

01. (a)	Are you a Manufacturer/ Trader? If Tenderer is a Manufacturer, (Registration Certificate is to be enclosed). <b>In case of a Dealer</b> , Authorization letter in Original from the Manufacturer and copy of Registration Certificate of the Manufacturer are to be uploaded along with the technical bid without fail.  Also, Tenderer should be registered under GST act. Copy of GST Registration Certificate (relevant State from where you supply the material) should be uploaded along with the Technical bid without fail.	YES / NO  GST NO :  PAN NO :
01. (b)	Location / place of Manufacturing Unit	
01. (c)	Daily production capacity	_____NOS.
01. (d.)	Quantity commitment per Month:	Min: _____ NOS Max: _____ NOS
02.	Do you have an Automatic Online Drying system at present? <b>(The offers from the units those who do not have this facility will not be considered)</b>	YES / NO
03.	<b><u>PAYMENT THROUGH RTGS:</u></b> Please inform whether we can make payment through RTGS Scheme. In case of acceptance, please provide the details in the consent letter which must be duly certified by your bankers.	AGREED / NOT AGREED  In case of acceptance, please provide the following details:- 1.Name of the Bank: 2.Branch Code : 3.Brance Name : 4.Account Number :
04 (a).	<b><u>TRANSPORT ARRANGEMENT:</u></b> It is the responsibility of the supplier to arrange transportation and freight charges shall be claimed only through invoice which will be settled while making payment for the material value.	AGREED / NOT AGREED

04 (b).	<b>DELIVERY TERMS:</b> <b>It is the responsibility of the supplier to deliver the material as per the purchase order and delivery schedule given by TNPL Unit - I.</b>	AGREED / NOT AGREED
05. (a)	<b>TENDER FEE :</b> Have you paid the Tender fee Amount of <b>Rs.590/- (Rupees Five hundred and Ninety only)</b> as per tender terms. If so, please furnish UTR No and date with name of the bank. <b>The UTR / Online payment transaction statement should be uploaded as .pdf file in the online portal :</b> <a href="https://tntenders.gov.in/nicgep/app">https://tntenders.gov.in/nicgep/app</a>  <b>NOTE:</b> Bidding schedule of those who fail to pay EMD is liable for rejection.	UTR NO(S):  DATE :  AMOUNT :  BANK :
05 (b)	<b>EMD AMOUNT:</b> Have you paid the E M D Amount of <b>Rs.50,000/- (Rupees Fifty Thousand Only)</b> as per tender terms. If so, please furnish UTR No and date with name of the bank. <b>The UTR / Online payment transaction statement should be uploaded as .pdf file in the online portal :</b> <a href="https://tntenders.gov.in/nicgep/app">https://tntenders.gov.in/nicgep/app</a>  <b>NOTE:</b> Bidding schedule of those who fail to pay EMD is liable for rejection.	UTR NO(S):  DATE :  AMOUNT :  BANK :
06.	<b>EXPERIENCE:</b> Have you supplied the Carton Lid & Tray for minimum period of past two years to any Paper Industries.  Please indicate the name and addresses of the factories to whom you have supplied for the past 2 years with supporting documents (Photo copy of purchase orders to be uploaded).	Yes / No.  Total Yrs of experience : _____ Yrs  Proof of documents uploaded / not uploaded
07.	Have you supplied <b>TNPL COPIER A4-70 GSM &amp; A4 80 GSM 10 REAMS CARTON LID &amp; TRAY</b> to TNPL previously. If so, furnish order particulars and quantity supplied.	Submitted / Not Submitted
08.	<b>FINANCIAL STATUS:</b> Please give your <b>sales turnover for the past 3 years along with supporting documents.</b> Please upload the documentary proof for past 3 years Sales Turnover.	Submitted / Not Submitted
09.	Tenderer should provide an audited balance sheet / IT return acknowledgement copies for the past 3 years without fail.  Audited Balance sheet / IT Return Acknowledgement copies should be uploaded.	UPLOADED / NOT UPLOADED

**TENDER.NO:242513002591**
**[3]**

10.	<p><b><u>STATUS OF ORGANISATION:</u></b> Partnership / proprietorship / private limited company / Public Limited Company / Public undertaking. (Please furnish the name and address of proprietor/partners in case of proprietor / partnership concern).</p> <p><b>In case of SSI unit, please furnish the Registration Number with date and copy of Registration Certificate</b></p> <p><b>In case of Small, Micro &amp; Medium Enterprises, please put tick (√)</b></p> <p><b>(If applicable , pl. provide Registration no</b></p>	<p>SMALL <input type="checkbox"/> MEDIUM <input type="checkbox"/></p> <p>MICRO <input type="checkbox"/></p> <p>NOT APPLICABLE <input type="checkbox"/></p> <p>Registration No:</p>
11. (a)	<p><b><u>QUANTITY REDISTRIBUTION:</u></b> Depending on the changes in production plan, P.O quantities may be redistributed suitably within the available sizes/Quantities and without altering the overall P.O value.</p>	<p>AGREED / NOT AGREED</p>
11 (b)	<p>Minimum time required to commence Supplies:</p>	<p>_____ Days</p>
12. (a)	<p><b><u>VALIDITY OF OFFER AND RATE:</u></b> Agreeable to keep the quotation valid for a minimum period of <b>90 Days from the date of Reverse Auction held / opening of Price Bid.</b></p>	<p>AGREED / NOT AGREED</p>
12 (b)	<p>The rate quoted should be valid for a period of <b>One year</b> from the date of order released by TNPL . <u>Offers of those who do not agree for <b>One year validity</b> will not be qualified in the tender.</u></p>	<p>AGREED / NOT AGREED</p>
12 (c)	<p>During the validity period of the order released by TNPL Unit-I, no price increase will be asked except in the case of statutory levies like GST.</p>	<p>AGREED / NOT AGREED</p>
13.	<p><b><u>QUALITY :</u></b> Can you supply the material strictly as per the TNPL specification?</p>	<p>YES / NO</p>
14.	<p><b><u>REJECTION OF MATERIAL:</u></b> In case of rejection, time required for replacement shall be 7 days from the date of intimation. The rejected material shall be taken back within 7 days from the date of intimation. Otherwise, the rejected material will be sent back to you at your risk and cost without any financial commitment to TNPL.</p>	<p>AGREED / NOT AGREED</p>



TENDER.NO:242513002591

[4]

15.	<p><b>SAMPLE:</b> Whether sample has been sent as per tender conditions. If so, please furnish the mode/date of dispatch with details/date of delivery at TNPL.</p> <p>Those whose sample is not received within the stipulated date and whose sample is not found acceptable their offers will not be considered. If sufficient quantity of sample is not received, their bid will not be considered.</p>	<p>SAMPLE SUBMITTED / NOT SUBMITTED</p> <p><b>IF SUBMITTED (DETAILS) :</b></p> <p>-----</p> <p>-----</p>
16.	<p><b>SPLITTING OF ORDER:</b> TNPL reserves the right to place order for the full tender quantity or part quantity thereof or split the order on more than one vendor or to place trial order in case of new vendors at its sole discretion.</p>	<p>AGREED / NOT AGREED</p> <p>MAXIMUM: _____NO</p> <p>MINIMUM: _____NO</p>
17.	<p><b>DECLARATION:</b> Whether the partners or directors or proprietor as the case may be of the company are related to any of the Employees of TNPL.</p> <p>In case the partners or directors or proprietor of the company are related to any of the employees of TNPL, a declaration to this effect giving the details of the name of the Employee, relationship etc., should be provided separately without which the offer will not be considered.</p>	<p>YES / NO</p>
20.	<p><b>Supplier should possess Energy, Environment and / or Quality Standard Certificate as applicable to their line of Business</b> (ISO 50001: 2018, ISO 14001 : 2015 and ISO 9001: 2015). If so, please provide the supporting documents of the same.</p>	<p>YES / NO</p> <p><b>DOCUMENTS ENCLOSED / DOCUMENTS NOT ENCLOSED</b></p>



I/We hereby declare that the particulars furnished above are true and correct to the best of my/our knowledge and agree to all the terms and conditions of TNPL Tender No: **242513002591**.

**NOTE:**

- The due date for submission of completed tender document online in e-procurement portal, <https://tntenders.gov.in/nicgep/app> is **22.08.2024 at 3.00 PM.**
- No late tender will be entertained. TNPL will not be responsible for any other delay in submission of bid through NIC on due date and in time.
- **The BOQ template (Price Bid Template)** must not be modified/replaced by the bidder and the same should be uploaded after filling the relevant columns, else the bid is liable for rejection. Bidders are allowed to enter the Bidder Name and Values only.
- The signed colour scanned copy of techno-commercial document to be uploaded in the online procurement portal <https://tntenders.gov.in/nicgep/app>

I/We accept all the terms and conditions contained in TNPL Tender No. **242513002591**

DATE :	(SIGNATURE WITH SEAL)
ADDRESS FROM WHERE YOU RAISE INVOICE  (In case of placement of order) :	
PHONE NO:	
CONTACT PERSON:	
MOBILE NO:	
FAX NO :	
E-Mail :	

**TENDER NO:242513002591****ANNEXURE – V  
PRICE BID SCHEDULE (BOQ)**

To

M/s. Tamil Nadu Newsprint and Papers Limited  
Kagithapuram – 639 136, Karur District**Sub: Supply of TNPL COPIER A4-70 GSM & A4 80 GSM 10 REAMS CARTON LID & TRAY - Reg**I/We hereby request you to quote **online** as per the **BOQ** and **upload the same with digital signature**:

The price to be quoted in INR in the BOQ (Excel file) and uploaded in the online portal.

S. No	Material Description	Name of the bidding firm		Freight Charges (Rs. P)	CGST in %	SGST in %	IGST in %
		UOM	Basic Price for Lid & Tray (Rs. P)				
1.	TNPL COPIER A4-70 GSM & A4 80 GSM 10 REAMS CARTON LID & TRAY	NO	Basic Price to be quoted only in E-portal	Freight charges (in numeric value) to be quoted only in E-portal	CGST (in percentage) to be quoted only in E-portal	SGST (in percentage) to be quoted only in E-portal	IGST (in percentage) to be quoted only in E-portal

**Note:**

1. Tenderer should quote the rate per **Number** on FOR Kagithapuram basis.
2. Tenderer should quote only numeric value in Freight charges. In case freight charges is included in the basic rate, then tenderer should enter as “0” in the Freight column.
3. Tenderer should quote applicable CGST, SGST and IGST in percentage (%) only.

The price Bid has been given as a BOQ format with the tender document. The BOQ (Protected Excel sheet) is to be downloaded and to be filled by the Bidder. Bidders are required to download the BOQ file, open it and fill the Blue colored (unprotected) cells with their respective financial quotes and other details (such as name of the Bidder etc). No other cells should be changed. Once the details have been completed, the Bidder should save it and submit it online, **without changing the file name**. If the BOQ file is found to be modified by the Bidder, the Bid will be rejected.

All other terms and conditions are as per the above Tender.

**I / We have read and understood all the terms and conditions of above tender and agree to abide by all of them.**

The price bid to be offered in the online excel format (BOQ) provided in the E-procurement portal and uploaded in the online portal with Digital signature.

Place:

**(Signature with seal)**

Date:

Address: